

## EVB-USB82514-QFN36 Evaluation Board User Manual (Revision B)

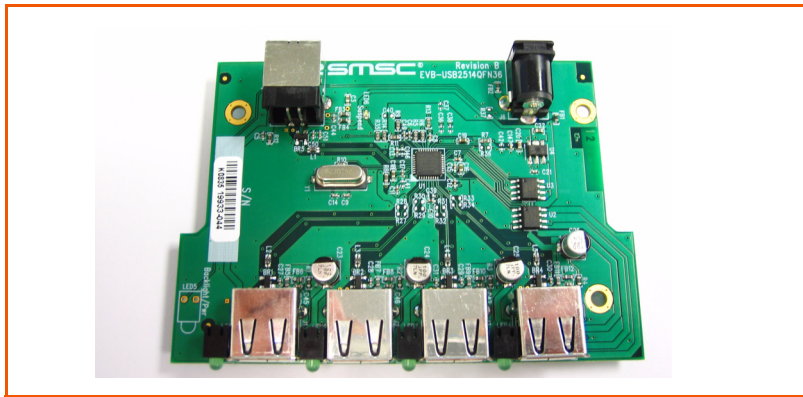

Copyright © 2009 SMSC or its subsidiaries. All rights reserved.

Circuit diagrams and other information relating to SMSC products are included as a means of illustrating typical applications. Consequently, complete information sufficient for construction purposes is not necessarily given. Although the information has been checked and is believed to be accurate, no responsibility is assumed for inaccuracies. SMSC reserves the right to make changes to specifications and product descriptions at any time without notice. Contact your local SMSC sales office to obtain the latest specifications before placing your product order. The provision of this information does not convey to the purchaser of the described semiconductor devices any licenses under any patent rights or other intellectual property rights of SMSC or others. All sales are expressly conditional on your agreement to the terms and conditions of the most recently dated version of SMSC's standard Terms of Sale Agreement dated before the date of your order (the "Terms of Sale Agreement"). The product may contain design defects or errors known as anomalies which may cause the product's functions to deviate from published specifications. Anomaly sheets are available upon request. SMSC products are not designed, intended, authorized or warranted for use in any life support or other application where product failure could cause or contribute to personal injury or severe property damage. Any and all such uses without prior written approval of an Officer of SMSC and further testing and/or modification will be fully at the risk of the customer. Copies of this document or other SMSC literature, as well as the Terms of Sale Agreement, may be obtained by visiting SMSC's website at <http://www.smcs.com>. SMSC is a registered trademark of Standard Microsystems Corporation ("SMSC"). Product names and company names are the trademarks of their respective holders.

**SMSC DISCLAIMS AND EXCLUDES ANY AND ALL WARRANTIES, INCLUDING WITHOUT LIMITATION ANY AND ALL IMPLIED WARRANTIES OF MERCHANTABILITY, FITNESS FOR A PARTICULAR PURPOSE, TITLE, AND AGAINST INFRINGEMENT AND THE LIKE, AND ANY AND ALL WARRANTIES ARISING FROM ANY COURSE OF DEALING OR USAGE OF TRADE. IN NO EVENT SHALL SMSC BE LIABLE FOR ANY DIRECT, INCIDENTAL, INDIRECT, SPECIAL, PUNITIVE, OR CONSEQUENTIAL DAMAGES; OR FOR LOST DATA, PROFITS, SAVINGS OR REVENUES OF ANY KIND; REGARDLESS OF THE FORM OF ACTION, WHETHER BASED ON CONTRACT; TORT; NEGLIGENCE OF SMSC OR OTHERS; STRICT LIABILITY; BREACH OF WARRANTY; OR OTHERWISE; WHETHER OR NOT ANY REMEDY OF BUYER IS HELD TO HAVE FAILED OF ITS ESSENTIAL PURPOSE, AND WHETHER OR NOT SMSC HAS BEEN ADVISED OF THE POSSIBILITY OF SUCH DAMAGES.**

## 1 Overview

The SMSC Automotive Grade USB 2.0 4-Port Hub is designed, fabricated, tested, characterized and qualified for automotive applications. The USB82514 is a low-power, OEM configurable, MTT (multi-transaction translator) hub controller IC with 4 downstream ports for embedded USB solutions. The USB82514 is a USB 2.0-compliant MultiTRAK™ hub that supports low-speed, full-speed, and hi-speed downstream devices. The EVB-USB82514-QFN36 evaluation board demonstrates a stand alone application for the hub with all of the features listed below as well as the advanced power saving options and configurable port assignments.

### 1.1 Features

- Low pin count: 36-pin QFN package
- Hi-Speed (480 Mbits/s), Full-Speed (12 Mbits/s), and Low-Speed (1.5 Mbits/s) compatible
- Operation from a single voltage (+5.0 V, regulated) 'wall wart' external power supply
- Low cost 4-layer design: two outer signal layers, power and ground inner layers
- Optional pull-up resistors for disabling individual downstream ports
- Self-powered operation
- Multi-TT enabled
- Supports internal default hub configuration
- Single onboard +3.3 V regulator
- Single crystal clock source
- Individual port over-current sensing
- Individual port power control
- Port OCS/port power control interface with LEDs for port power indication
- Red LED indicator for active hub state (not suspend)
- EMI suppression provided by ferrite beads, selection of capacitors, and internal power/ground layers
- ESD protection up to 25 kilovolts of direct contact to USB signals provided with diode bridges and common mode chokes

### 1.2 General Description

The EVB-USB82514-QFN36 evaluation board is a low-cost evaluation platform featuring the USB82514 4-port low-power, hi-speed USB 2.0 hub with MultiTRAK™ technology. The platform is designed to robustly demonstrate the unique features of this device using a low-cost PCB implementation with individual port power control. The EVB-USB82514-QFN36 is designed with efficient power usage for the implementation of a hi-speed USB hub with minimal bill-of-materials. Schematics, layout, and bill-of-materials are included to minimize new product development time.

Revision B of the EVB-USB82514-QFN36 features a four-layer printed circuit board to improve coupling between power and ground to reduce EMI. Ferrite beads have been added on all connector ground and power nets. Protective diode bridges and common mode chokes have been added to all USB signals.

## 2 Hardware Configuration

### 2.1 Hardware Description

The EVB-USB82514-QFN36 has one onboard regulator which generates 3.3 volts from a 5 volt power supply. An alternate footprint U4 has been added for commercial temperature range. The U5 footprint corresponds to the automotive temperature range with a larger package and has ties into the ground plane for better thermal dissipation. The USB82514 generates its own on-chip 1.8 volt supply. The USB82514 hub consumes power from the 3.3 volts supply while the Micrel<sup>®</sup> Dual-Channel Power Distribution Switch (MIC2026) consumes power from the 5 volt supply. The MIC2026 power distribution switch supplies downstream power to each attached device.

#### 2.1.1 Port Assignment

Downstream ports are numbered one through four with individual port power controllers. The port power controllers provide 5 volts of power with over-current protection to the downstream devices. Upstream and downstream port connectors have USB 2.0 compliant decoupling, filtering for EMI on signal ground and power, and a separate shield ground. ESD protection for USB signals is provided by diode bridges and common mode chokes. This feature provides protection of up to 25 kilovolts of direct contact to USB signals.

Optional pull-up resistors can be placed to disable a USB port. Please refer to the schematics in [Figure 2.1](#) and [Figure 2.2](#) for implementation.

#### 2.1.2 HUB Configuration

The EVB-USB82514-QFN36 has been configured to support internal default configuration with strapping options enabled as determined by the state of CFG\_SEL1 and CFG\_SEL0 pins immediately after reset. The internal 1.8 V regulator supplies voltage to the oscillator and PLL is turned off during suspend to minimize suspend current.

#### 2.1.3 Port Power LEDs

LEDs one through four can be arranged to indicate when port power is available. This feature is optional and consumes power in suspend mode. The recommendation is to leave this feature unpopulated for low-cost and low-power implementations.

#### 2.1.4 Active State LED

LED 6 is a red LED that indicates when the hub is not in suspend.

#### 2.1.5 Powered State/Backlight LED

An optional LED, LED5, indicates when 5 volts of power are present.

#### 2.1.6 Connector Description

The EVB-USB82514-QFN36 has a standard set of USB style connectors:

- One type B connector for upstream ports
- Four type A connectors for downstream ports

Power is supplied via a 2.0 mm power jack. Please refer to [Table 2.1, "Connector Descriptions"](#) for a list of all of the connectors. For more details on the pinout of the connectors please refer to the schematics in [Figure 2.1](#) and [Figure 2.2](#).

## 2.1.7 Layout Considerations

The EVB-USB82514-QFN36 is a low-power, hi-speed USB 2.0 compliant hub on four PCB layers. Please refer to [Table 2.2](#) for a list of the PCB stackup. All signals are routed on the top layer to demonstrate the simplicity of implementation. Differential signals from the USB82514 match the upstream and downstream port placement to simplify the routing of critical signals.

The top layer of the component side is shown in [Figure 2.1](#). The schematic includes silk screen information to identify component locations.

**Table 2.1 Connector Descriptions**

| CONNECTOR | TYPE              | DESCRIPTION       |
|-----------|-------------------|-------------------|
| J5        | USB B             | Upstream Port     |
| J1        | USB A             | Downstream Port 1 |
| J2        | USB A             | Downstream Port 2 |
| J3        | USB A             | Downstream Port 3 |
| J4        | USB A             | Downstream Port 4 |
| J6        | Power Jack 2.0 mm | +5 V Power Supply |

**Table 2.2 PCB Stackup**

| COMPONENT SIDE     |                         |
|--------------------|-------------------------|
| Soldermask         |                         |
| Layer 1            | 1.3 - 2.3 oz., finished |
| pre-preg           | 4.0 - 4.5 mil FR-4      |
| Layer 2            | 1.0 oz., nominal        |
| core               | 28 mil FR-4             |
| Layer 3            | 1.0 oz., nominal        |
| pre-preg           | 4.0 - 4.5 mil FR-4      |
| Layer 4            | 1.3 - 2.3 oz., finished |
| Soldermask         |                         |
| <b>Solder Side</b> |                         |

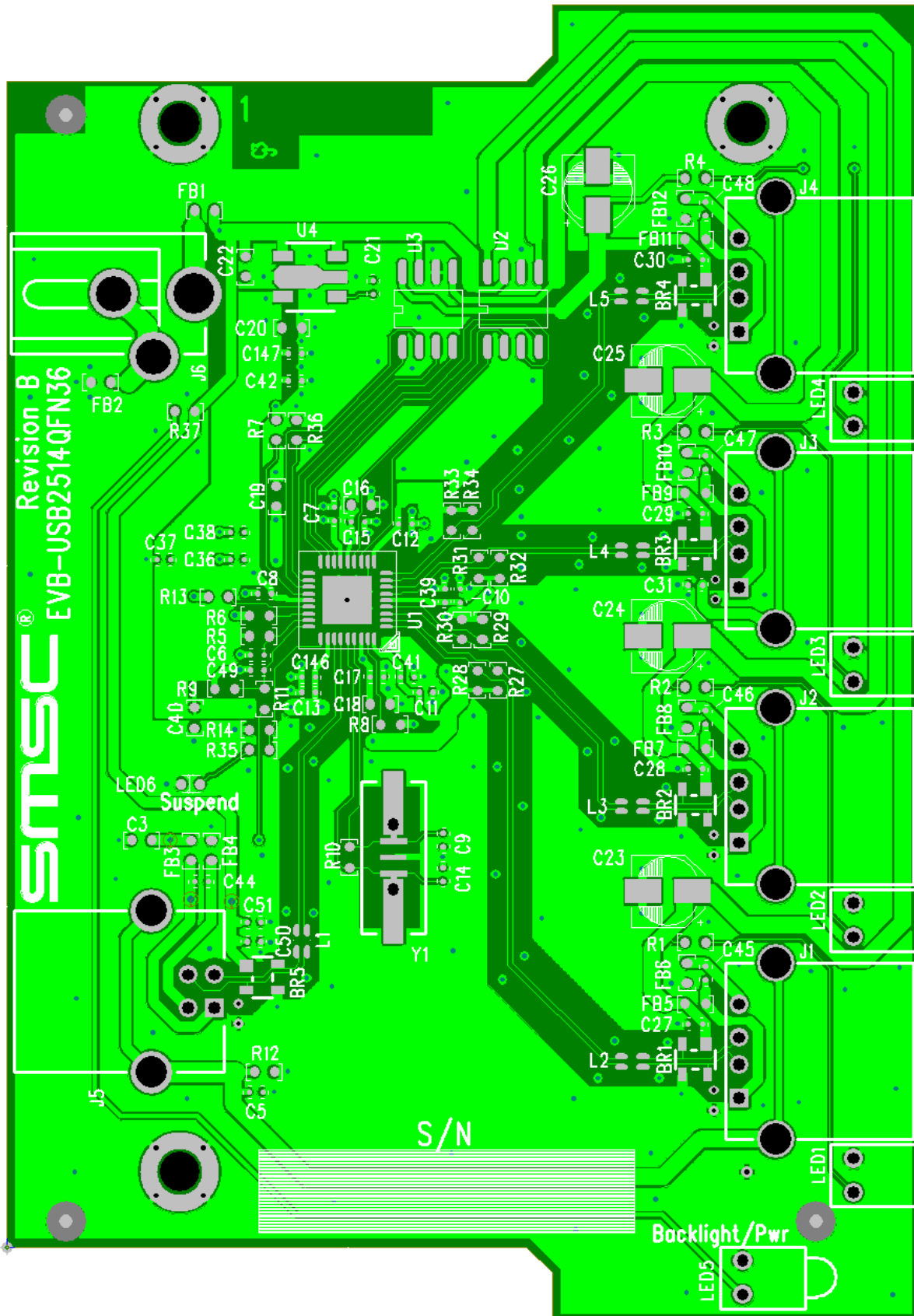

Figure 2.1 EVB-USB82514-QFN 36-Pin Component Side Top Layer

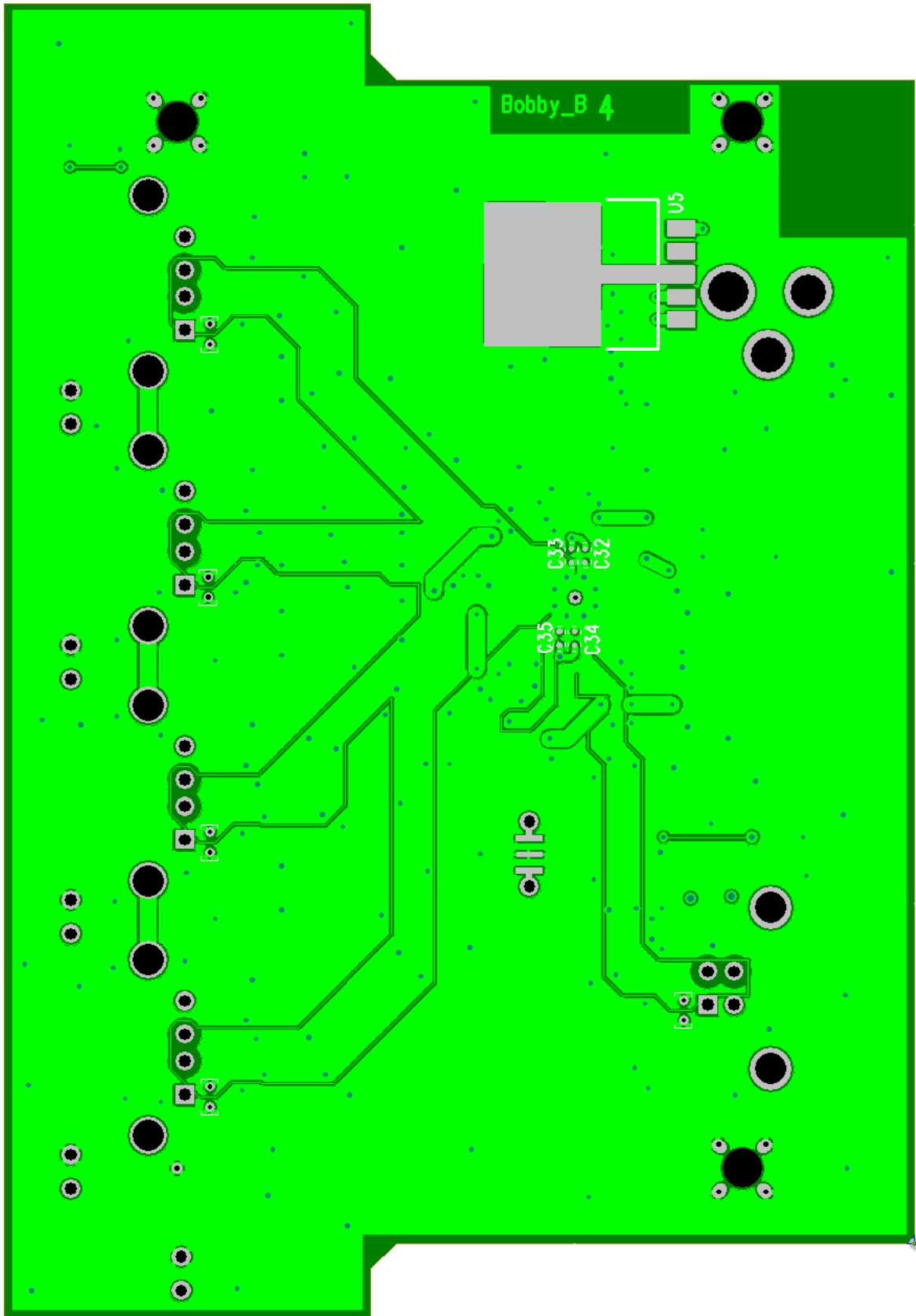

Figure 2.2 EVB-USB82514QFN 36-Pin Solder Side Bottom Layer



### 3 Further Information

For more information on SMSC automotive products, including integrated circuits, software, and MOST development tools and modules, visit our web site: <http://www.sm-sc-ais.com>. Direct contact information is available at: <http://www.sm-sc-ais.com/offices>.

**SMSC Europe GmbH**

Bannwaldallee 48  
D-76185 Karlsruhe  
Germany

**SMSC**

80 Arkay Drive  
Hauppauge, New York 11788  
USA

**Technical Support**

Contact information for technical support is available at: <http://www.sm-sc-ais.com/contact>.